



SAFETY, INSTALLATION, AND OPERATIONS MANUAL

North America and Europe



This document applies to following Solaria Photovoltaic Modules:

Solaria 270W/275W/280W

Safety, Installation, and Operations Manual

1.0 INTRODUCTION

This document provides safety and installation information for Solaria's frameless modules.

Read this document before installing, wiring, or using this product. Failure to comply with these instructions will invalidate the Solaria Limited Warranty and may cause loss or damage or injury.

1.1 LIMITED WARRANTY

Module limited warranty is described in *The Solaria Corporation Warranty Certificate Document*.



2.0 SAFETY PRECAUTIONS

Before installing the frameless modules, read all safety instructions in this document.

- ▲ Modules produce direct current (DC) when exposed to light. Direct current can arc across gaps and may cause injury or death if improper connection or disconnection is made, or if contact is made with exposed leads. Do not connect or disconnect modules when current from the modules or an external source is present.
- ▲ Solaria modules are designed for grid-connected applications only and should not be used in systems with batteries/charge controllers. Do not operate the modules in a short circuit condition for extended periods of time.
- ▲ Do not artificially expose additional high intensity sunlight directly on the module.
- ▲ Please do not remove the connector caps until the modules are connected. The caps prevent any dirt clogging the connector tips, which may result in electrical blockage.
- ▲ Do not disconnect modules while under load.
- ▲ All installations must be performed in compliance with local, regional, national and international statutory regulations, guidelines, norms and code requirements.
- ▲ There are no user serviceable parts within the module. Do not attempt to repair any part of the module.
- ▲ Installation should be performed by authorized personnel only.
- ▲ Use insulated tools to reduce risk of electric shock. Do not touch terminals with bare hands.
- ▲ Do not stand on, drop, or allow objects to fall on modules.
- ▲ Do not install or handle modules when they are wet or during periods of high wind.
- ▲ Before installing your system, contact local authorities to determine necessary permit, installation and inspection requirements.
- ▲ Module support structures should be wind rated per local code and approved for use by the local authorities.



2.1. FIRE RATING AND SAFETY

- ▲ Solaria modules are Class C fire rated and certified by an independent third party testing laboratory.
- ▲ The modules are qualified for Application Class A: Hazardous voltage (IEC 61730: higher than 50V DC; EN61730: higher than 120V), hazardous power applications (higher than 240W) where general contact access is anticipated (modules qualified for safety through EN IEC 61730-1 and -2 within this application class are considered to meet the requirements for Safety Class II)
- ▲ Refer to your local authority for guidelines and requirements for building or structural fire safety.
- ▲ The roof construction and installation may affect the fire safety of a building: improper installation may contribute to hazards in the event of fire.
- ▲ **The Solaria frameless modules are not designed for roof top open rack fixed tilt mountings.**
- ▲ It may be necessary to use components such as earth fault circuit breakers, fuses and circuit breakers.
- ▲ Do not use modules near equipment or locations where flammable gases can be generated or can collect.

2.2. ADDITIONAL ARTIFICIALLY CONCENTRATED SUNLIGHT SHALL NOT BE DIRECTED ON THE MODULE

3.0 ELECTRICAL INSTALLATION

CAUTION: AVOID ALL ELECTRICAL HAZARDS WHEN INSTALLING, WIRING, OPERATING, AND MAINTAINING A MODULE OR MODULE ARRAY.

Refer to Section 2 for more information.



- ▲ Avoid all electrical hazards when installing, wiring, operating and maintaining a module or module array.
- ▲ If the total DC voltage exceeds 100V, the system must be installed, commissioned and maintained by a licensed electrician unless local electrical codes determine otherwise.
- ▲ Contact with a DC voltage is potentially hazardous.
- ▲ Do not use modules of different electrical or physical configurations in the same system or array.
- ▲ **Series Connection:** The modules may be wired in series to produce the desired voltage output. Do not exceed the maximum system voltage indicated on the module label.
- ▲ **Parallel Connection:** The modules maybe combined in parallel to produce the desired current output. Each series string or module may be required to be fused prior to combining with other strings. The maximum fuse size allowed is noted on the module label.
- ▲ Connection cables and wiring shall be supported with plastic or rubber cable ties and clips to the module support structures. Module junction boxes and metal cable ties should not be used to support cables and wiring.
- ▲ Under normal conditions, a photovoltaic module is likely to experience conditions that produce more current and/or voltage than reported at Standard Test Conditions. Accordingly, the values of I_{sc} and V_{oc} marked on this module should be multiplied by a factor of 1.25 when determining component voltage ratings, conductor capacities, fuse sizes, and size of controls connected to the PV output.

- ▲ Refer to section 690-8 of the National Electric Code (NEC) for additional multiplying factor of 125% (80% de-rating) which may be applicable.
- ▲ Wire recommendations; single conductor cable, type USE-2 (non-conduit) 10-12AWG (4-6mm²) with minimum 90°C rating and sunlight UV protected.
- ▲ All Solaria modules are equipped with factory locking connecting cables. Modules have been designed to be easily connected. **The locking connectors are not to be disconnected under load.** The proper procedure to disconnect the module locking connectors is as follows: Turn off of the inverter(s), shut off the module DC disconnect(s) and then disconnect the locking connectors using an approved tool set. To re-install, connect the module locking connectors, turn on the module DC disconnect(s) and turn on the inverter(s).
- ▲ The electrical installation shall be in accordance with CSA C22.1, Safety Standard for Electrical Installations, Canadian Electrical Code, Part 1.
- ▲ Match the polarities of the cables and terminals when making connections; failure to do so may result in damage to the modules and other electrical equipment.
- ▲ A properly rated and certified over-current device must be connected in series with each module or string of modules when reverse currents can exceed the value of the maximum protective fused value noted on the module label. The rating of the over-current device shall not exceed the value of the maximum protective fuse rating specified on the module label.
- ▲ All Solaria modules are factory supplied with bypass diodes located in the junction box. These diodes protect the shaded cells within a module. Partial shading of a single module in a string of modules causes reverse voltage across the shaded cells. This results in current being forced through the shaded cells causing module heating and severe power loss. The bypass diodes provide a low-resistance current path through the shaded cells thus minimizing module heating and array current loss.
- ▲ The junction box is not designed or certified to be field accessible or maintainable and should under no circumstances be opened. Opening the junction box may void the module warranty.
- ▲ Note that connecting the module to a high current source, such as a battery, may damage or destroy the bypass diodes and render the module inoperative. Bypass diodes are not user replaceable.
- ▲ Solaria modules are not factory supplied with blocking diodes. Blocking diodes are placed between a PV module and battery to prevent battery discharge at night. Most PV charge controllers and inverters incorporate nighttime disconnect features.

	J-Box	Cable	Connectors
Model	Bizlink / Sunbolts S419-2C2218-314A	Bizlink / Sunbolts PV Wire - TYO-2100	Bizlink / Sunbolts (+)S418-32B-051 (-)S418-31B-051
Size	24.5 x 101mm ²	1x4mm ²	(+) 18.8 x 55.7mm ² (-) 18.8 x 64.4mm ²
Type	4 Rail / 3 Diode Protection IP65	2 PFG 1169 600 / 1000 V	Protection IP67
Temp Rating	TUV: -40 to 85°C UL: -40 to 90°C	-40 to 90°C	TUV: -40 to 85°C UL: -40 to 90°C

3.1. GROUNDING (GRID-TIED APPLICATIONS)

- Before installing your solar system, contact local authorities to determine the necessary system hardware grounding requirements.
- Solaria frameless modules do not require grounding.

4.0 MODULE MOUNTING

The Solaria Corporation Limited Warranty for PV Modules is contingent upon modules being mounted in accordance to the requirements described in this section.

4.1. SITE CONSIDERATIONS

Solaria frameless modules should be tracker mounted in locations which meet following requirements.

- Module should not be mounted in locations where it will be in direct contact with salt water.
- When choosing a site, avoid obstructions which could cast shadows on the modules.



4.2. FRAMELESS MECHANICAL INSTALLATION

CAUTION: THE SOLARIA FRAMELESS MODULES SHOULD BE HANDLED WITH CARE DURING REMOVAL FROM PACKAGING AND INSTALLATION. HEAVY IMPACT ON THE FRONT, BACK, OR EDGES COULD RESULT IN DAMAGE TO THE MODULE. DO NOT ATTEMPT TO INSTALL THE MODULES IN HIGH WINDS OR WET CONDITIONS.

Solaria frameless module mounting configurations must meet the following requirements:

- The entire frameless/clip/rail system used to mount Solaria frameless modules must satisfy the requirements of the twist test described in standard IEC1646 section 10.15, and the mechanical load tests described in standard IEC1646 section 10.16.
- The mounting system design must provide adequate support for the frameless module to prevent damage from occurring when the module is subjected to site wind loads.
- Modules should be secured to the tracker open rack mounting structure using four aluminum frameless module clips, 100mm long minimum, that grasp the frameless module by at least 12mm. The retaining clips must each provide a minimum contact area of 12mm x 100mm and be lined with rubber to protect and grasp the module glass. The rubber must be 3mm thick minimum. Single sided glazing tape, at least 3mm thick, must be used between the module back sheet and the tracker mounting structure to provide adequate protection of both the front glass and back sheet materials. No direct contact of the tracker frame or rails is permitted against the back sheet or the edges of the frameless module. The center of the frameless mounting clips must be located on the long side of the frameless module between 390mm and 490mm from the edge. See figure below for allowed clip locations. The specified maximum load for the frameless modules is 2,400 PA. The module retaining clips must withstand a load of 127kgf each.

- All mounting structures must provide a flat plane for the frameless modules to be mounted, and must not cause any twist or stress to be placed on the module.

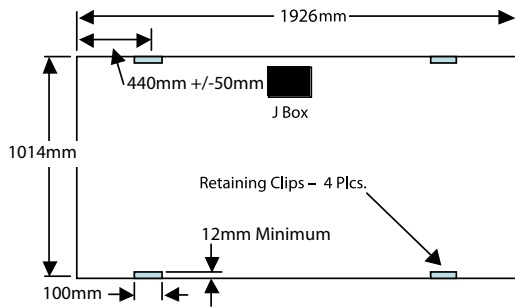

- Use four sets of stainless steel hardware (each set: M8 x 25mm long Socket Head Cap Screw, M8 hex nut, square nut, t-nut or equivalent, and an M8 spring lock washer). The socket head cap screw length will be dependent on the tracker support rail configuration. If the tracker support rails are oriented parallel to the long edge of the frameless module, they must provide an adequate area of flat plane for the frameless module to land on. This flat plane area must support the module a minimum of 25mm in from the edge of the module, at least at the four locations of the module retaining clips. If the

tracker support rails are not wide enough to provide this support, the support can be provided by using an aluminum shim plate beneath each of the four clip locations. The shims must have a load bearing capacity equal to the load bearing capacity of the retaining clips. See following figures:

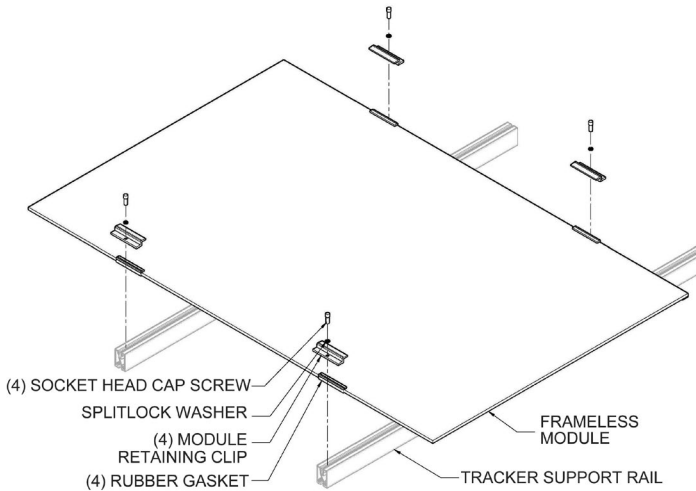

**EXPLODED ISOMETRIC ASSY VIEW-
RAILS PERPENDICULAR TO LONG EDGE OF MODULE**

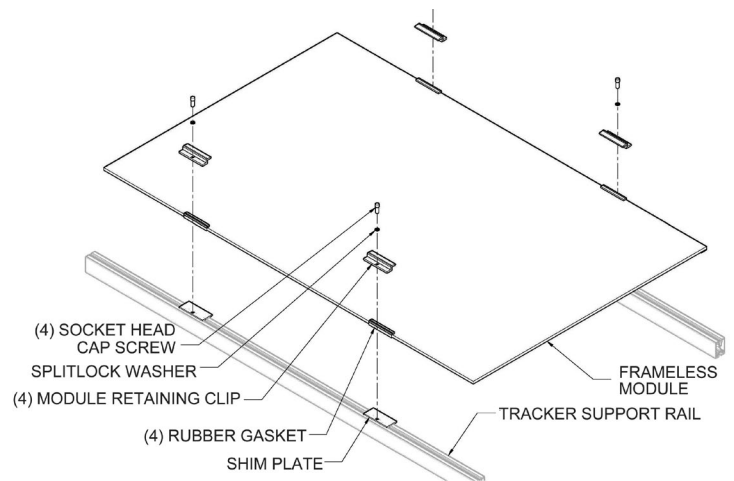

**EXPLODED ISOMETRIC ASSY VIEW-
RAILS PARALLEL TO LONG EDGE OF MODULE**

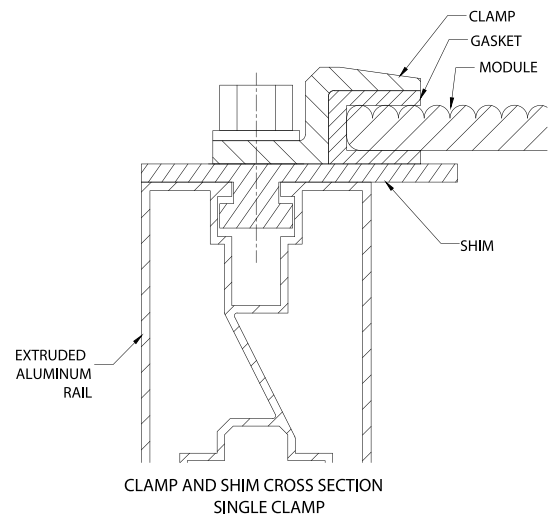
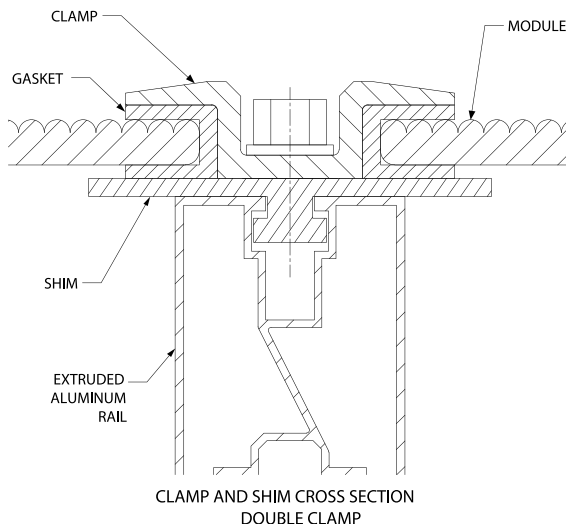

- Install the female threaded component (i.e. a threaded nut) on the tracker support rail as appropriate for the selected tracker.
- Insert the spring lock washer over the socket head cap screw, install through the retaining clip, and tighten down over the frameless module to a torque of 100 inch pounds.
- Use the following McMaster Carr stainless steel fasteners or equivalent:
 - #91292A148 M8 x 25mm long Socket Head Cap Screw
 - #91828A410 M8 hex nut
 - #92148A200 M8 spring lock washer
- The Solaria frameless modules must be tracker open rack mounted. **If other mounting means are employed this may affect product certification or the fire class ratings**
- For tracker open rack roof mounting, the modules should be mounted over a fire resistant covering rated for the application.
- Clearance of 7mm or more between frameless modules is required to allow for thermal expansion of the tracker rack mounting hardware.
- Always keep the back surface of the module free from any foreign objects or structural elements which could come into contact with the module.
- Ensure modules are not subject to wind or snow loads in excess of the maximum permissible loads and are not subject to excessive forces due to thermal expansion of the support structure.

4.3. MODULE DIRECTION AND TILT ANGLE

- Modules produce maximum energy when they are pointed directly to the Sun. Modules get maximum sunlight throughout the year if they face South in Northern Hemisphere and they face North in Southern Hemisphere.
- When mounted on a single axis tracker, modules may be tilted or kept horizontal. Tilting will produced more annual energy

4.4. MODULE ORIENTATION

- **Fixed Tilt Rack:** The Solaria modules are not designed for fixed tilt rack mounting – mounting in this manner will result in poor power production.
- **Horizontal Single Axis Tracker:** Modules should be tracker open rack mounted such that the cell lenses are in the North-South direction. In this orientation, the cell lenses are parallel to axis of rotation. This orientation is called Landscape Mount.

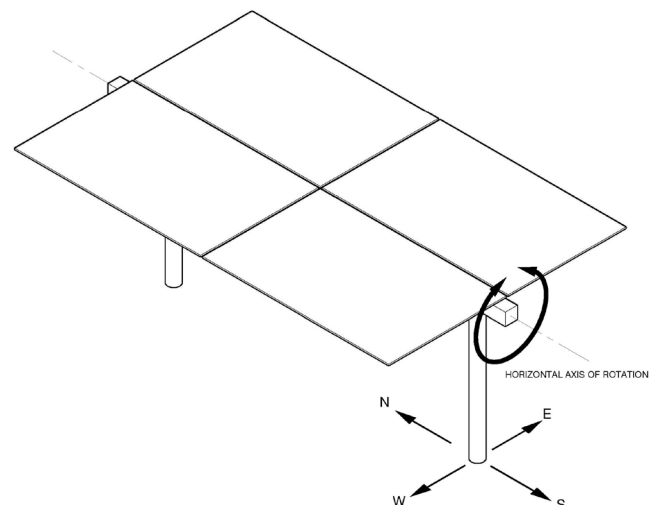

- **Azimuth Single Axis Tracker:** Modules should be tracker open rack mounted such that the cell lenses are **parallel to azimuth axis of rotation**. This orientation is called **Portrait Mount**.

Note: In this orientation, frameless module safety hooks maybe required to prevent the modules from slipping due to thermal expansion.

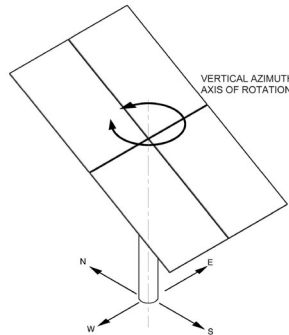

- **Dual Axis Tracker:** Modules should be tracker open rack mounted such that the cell lenses are **parallel to azimuth axis of rotation**. This orientation is called **Portrait Mount**.

Note: In this orientation, frameless module safety hooks maybe required to prevent the modules from slipping due to thermal expansion.

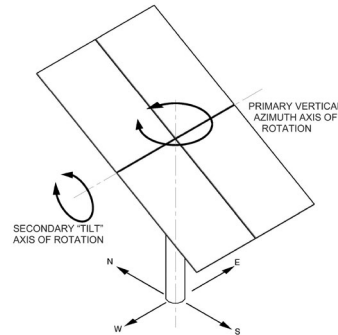

5.0 MAINTENANCE

Solaria modules are virtually maintenance free. Following simple maintenance steps will ensure reliable production of DC electric power for the expected life of the product.

- Inspect electrical and mechanical connections for safety and corrosion at least once every year.
- Under most weather conditions, normal rainfall is sufficient to keep the module glass surface clean. Modules that are mounted at small tilt angle will not self-clean as easily as modules that are mounted at large tilt angles. If dirt build-up becomes excessive, clean glass surface with water and soft cloth. Do not use harsh cleaning materials.
- Cleaning the back surface of the module is not necessary for proper operation. Should it be deemed necessary to clean the back surface, avoid penetrating the back sheet.

6.0 DISCLAIMER OF LIABILITY

- Since the use of this Safety, Installation and Operation Manual and the conditions or methods of installation, operation, use and maintenance of the module are beyond The Solaria Corporation control, The Solaria Corporation does not assume responsibility and expressly disclaims liability for loss, damage, injury or expense arising out of or in any connection with such installation, operation, use or maintenance of the module.
- The Solaria Corporation assumes no responsibility for any infringement of patents or other rights of third parties that may result from the use of the module. No license is granted by implication or otherwise under any patent or patent rights.
- The information in this Manual is based on The Solaria Corporation knowledge and experience and is believed to be reliable; but such information including the product specifications (without limitations) and suggestions do not constitute a warranty, expressed or implied. The Solaria Corporation reserves the right to make changes to the product specifications or this manual without prior notice.
- This document may be provided in multiple languages. If there is a conflict among versions, the English language version dominates.



7.0 ELECTRICAL SPECIFICATIONS*

ELECTRICAL PARAMETER	Solaria 280	Solaria 275	Solaria 270
	Peak Power, Pmax (Watts)	280	275
Open Circuit Voltage, Voc (V)	44.60	44.40	44.20
Short Circuit Current, Isc (A)	8.27	8.15	8.04
Voltage at Pmax (V)	35.90	35.60	35.10
Current at Pmax (A)	7.80	7.73	7.69
Max Series Fuse Rating (A)	15	15	15
Max System Voltage (V)	US600/IEC1000	US600/IEC1000	US600/IEC1000

MODEL: SOLARIA 270

Peak Power	(Pmax)	270	W
Voltage at Pmax	(Vmp)	35.10	V
Current at Pmax	(Imp)	7.69	A
Open Circuit Voltage	(Voc)	44.20	V
Short Circuit Current	(Isc)	8.04	A
Maximum Series Fuse		15	A

All ratings at standard test conditions: 1000 W/m², AM 1.5 spectrum, 25°C
Field connections, use min. 12 AWG copper wires insulated for 90°C min.

~ WARNING ~
ELECTRICAL HAZARD
Read and comply with
product installation manual.

440±50
(mm)

System Rear
Refer to Installation Manual

--- BARCODE ---

Serial number with traceability for date and place of
manufacture

UL Fire Rating Class C - IEC Safety Class II

Maximum System Voltage US-600V, IEC-1000V

Made in the USA
www.solaria.com
PSC3003-01

ELECTRICAL

Cells Monocrystalline

Bypass Diodes 3

Ratings 15 Amps each

Max Vrrm 45 Volts

Type Diotec SB1540

TEMPERATURE COEFFICIENTS

Isc 3.62 mA/°C

Imp -2.31 mA/°C

Voc -159.12 mV/°C

Vmp -161.46 mV/°C

Pmax -1.323 W/°C

- Specified power rating is +3/-2% of indicated value of Pmax under STC*
- All other electrical specifications are + or - 10% of indicated values under STC*
- *STC : Irradiance 1000 W/m², AM 1.5 spectrum, Cell Temperature 25^o C
- Module is rated for Application Class A

8. MECHANICAL DIMENSIONS:

- Frameless Module Weight: 74 lbs
- Nominal dimensions in millimeters and [inches] – Not Drawn to Scale

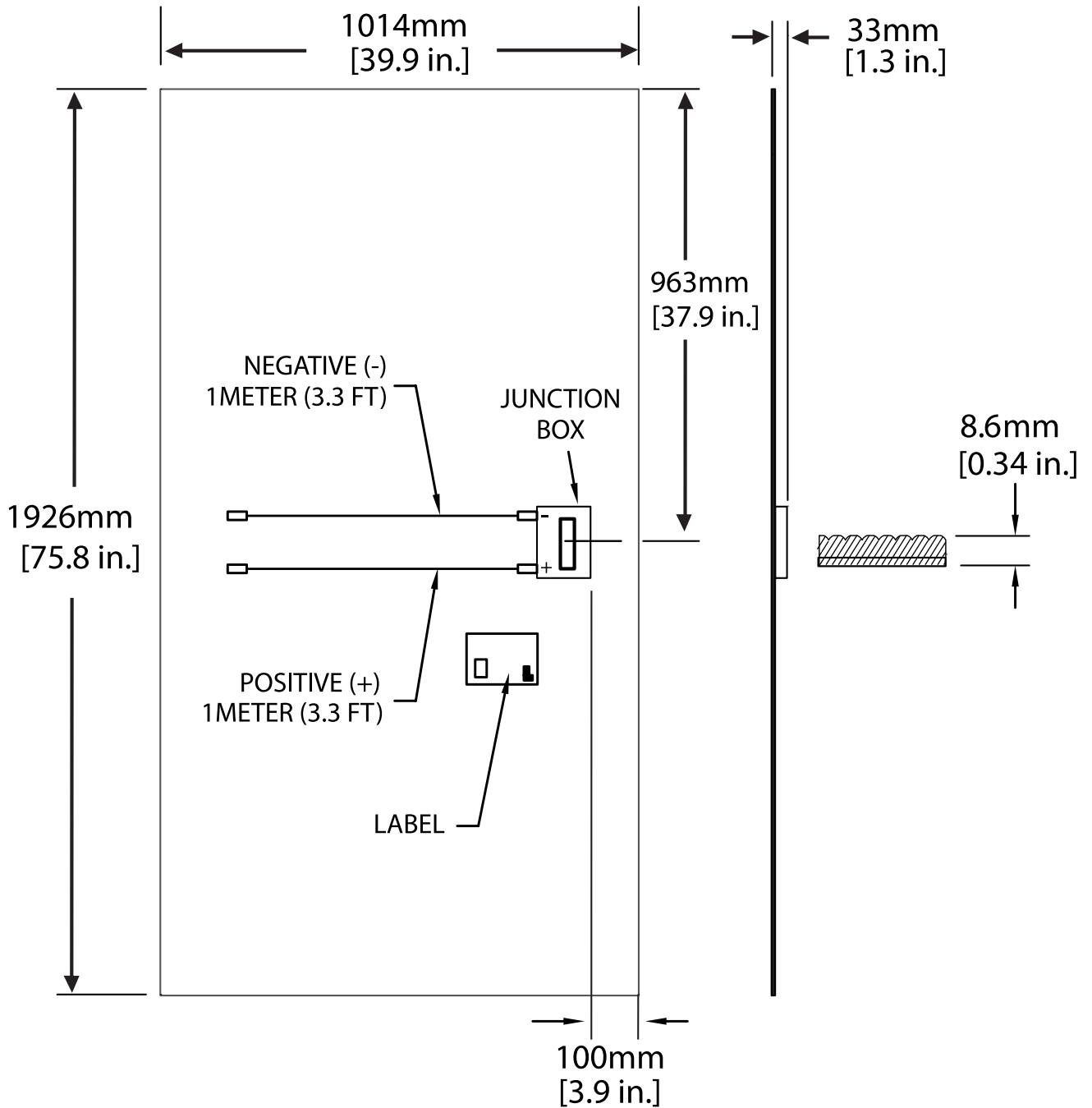



Solaria USA

6200 Paseo Padre Pkwy
Fremont, CA 94555
United States of America

T: +1-510-270-2500
F: +1-510-793-8388

Solaria Germany

Friedrichstr. 191/1. OG
D-10117 Berlin, Germany

T: +49 30 20659 151
F: +49 30 20659 200

Solaria India

202 SSH Pride, Plot 273
Road No. 78

Jubilee Hills, Hyderabad
AP 500096, India

T: +91 40 2355-4787
F: +91 40 2355-4883

www.solaria.com